

Manganese Dioxide Lithium Coin Batteries: Individual Specifications

CR1025

■ Dimensions(mm)

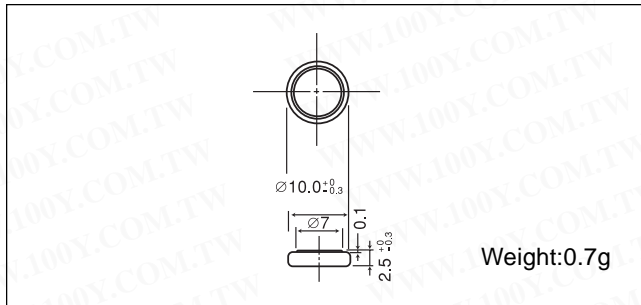

■ Specification

Nominal voltage (V)	3
Nominal capacity (mAh)	30
Continuous standard load (mA)	0.1
Operating temperature (C)	-30 ~ +60

■ Temperature Characteristics

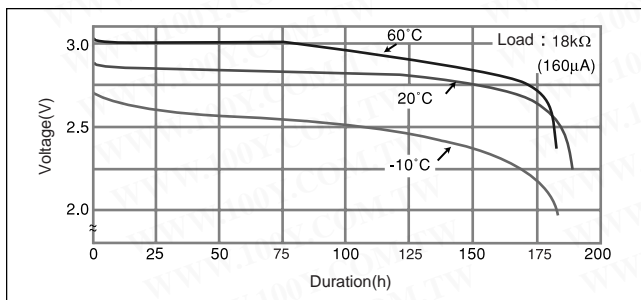

■ Operating voltage vs. load resistance (voltage at 50% discharge depth)

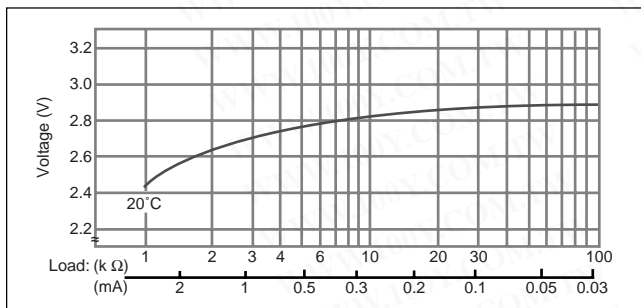

■ Capacity vs. load resistance

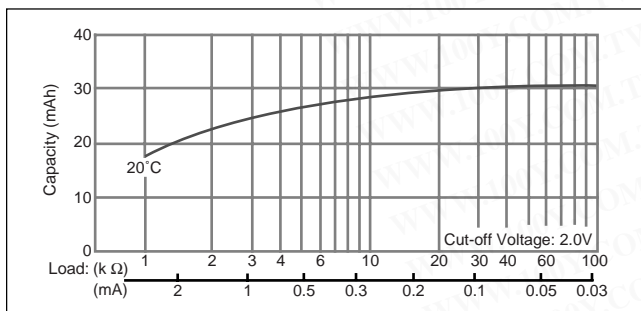

CR1216

■ Dimensions(mm)

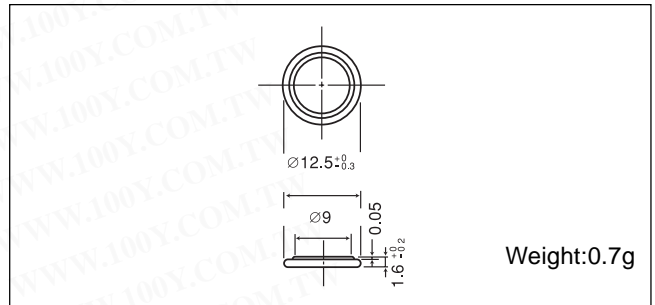

■ Specification

Nominal voltage (V)	3
Nominal capacity (mAh)	25
Continuous standard load (mA)	0.1
Operating temperature (C)	-30 ~ +60

■ Temperature Characteristics

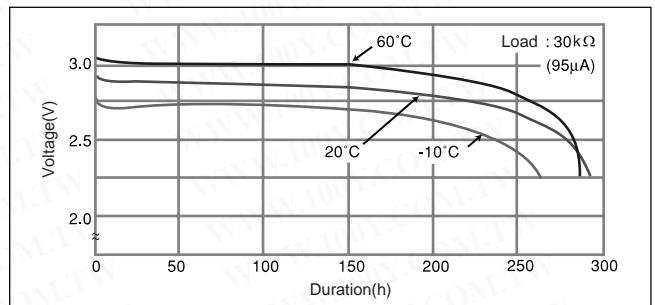

■ Operating voltage vs. load resistance (voltage at 50% discharge depth)

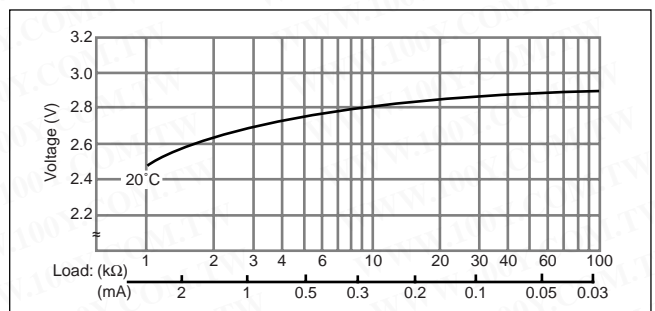

■ Capacity vs. load resistance

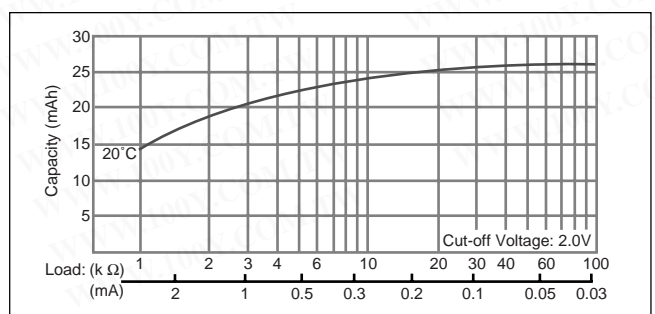

Manganese Dioxide Lithium Coin Batteries: Individual Specifications

CR1025

■ Dimensions(mm)

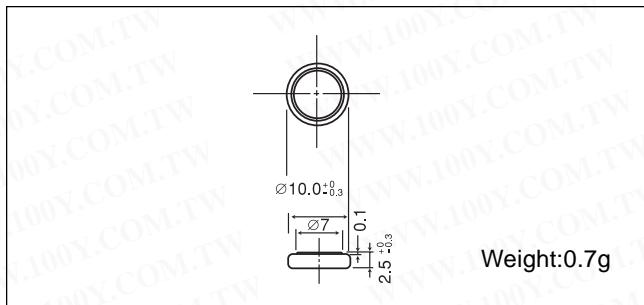

■ Specification

Nominal voltage (V)	3
Nominal capacity (mAh)	30
Continuous standard load (mA)	0.1
Operating temperature (C)	-30 ~ +60

■ Temperature Characteristics

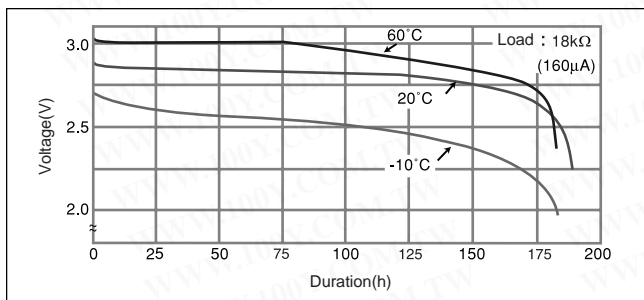

■ Operating voltage vs. load resistance (voltage at 50% discharge depth)

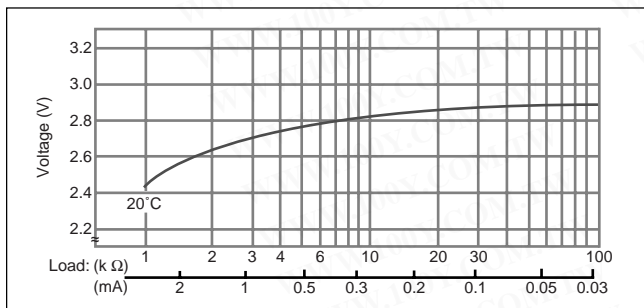

■ Capacity vs. load resistance

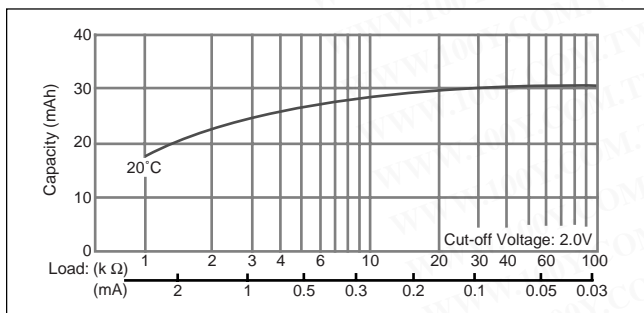

CR1216

■ Dimensions(mm)

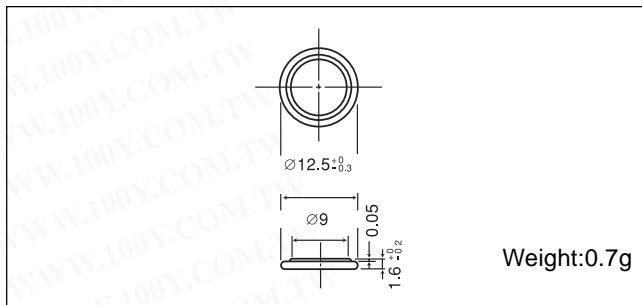

■ Specification

Nominal voltage (V)	3
Nominal capacity (mAh)	25
Continuous standard load (mA)	0.1
Operating temperature (C)	-30 ~ +60

■ Temperature Characteristics

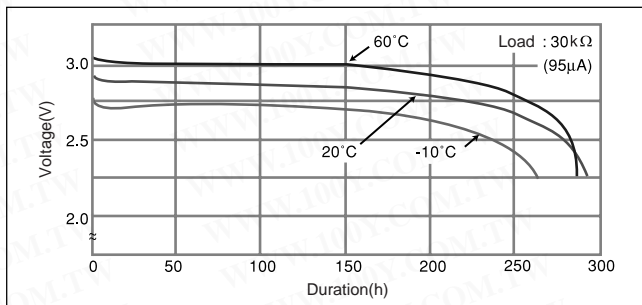

■ Operating voltage vs. load resistance (voltage at 50% discharge depth)

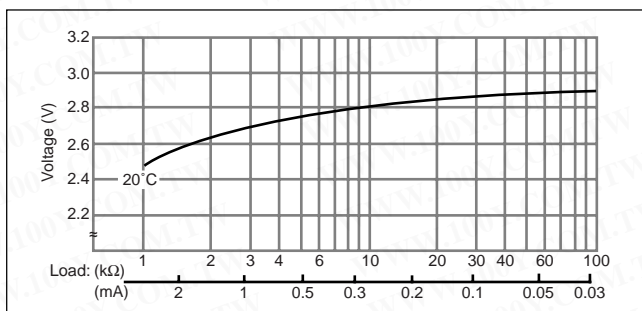

■ Capacity vs. load resistance

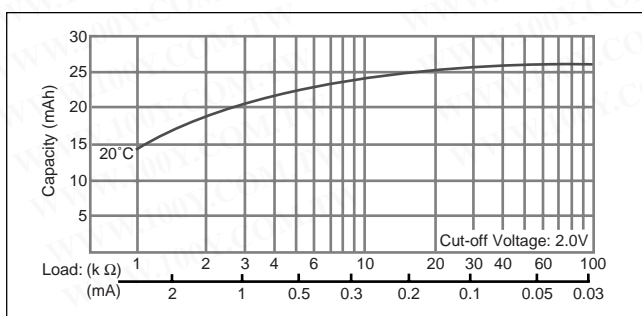

Manganese Dioxide Lithium Coin Batteries: Individual Specifications

CR1220

■ Dimensions(mm)

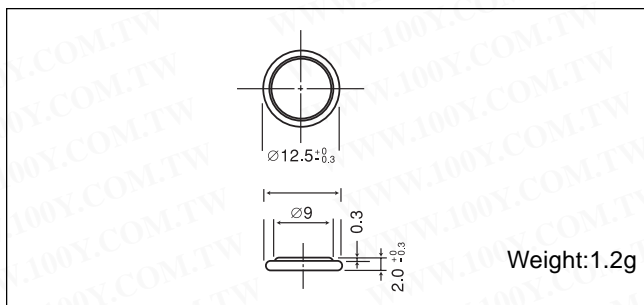

■ Specification

Nominal voltage (V)	3
Nominal capacity (mAh)	35
Continuous standard load (mA)	0.1
Operating temperature (C)	-30 ~ +60

■ Temperature Characteristics

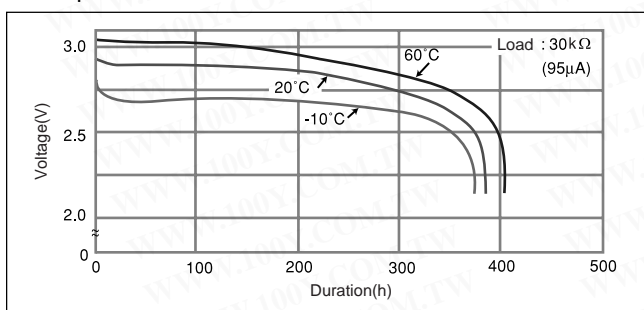

■ Operating voltage vs. load resistance (voltage at 50% discharge depth)

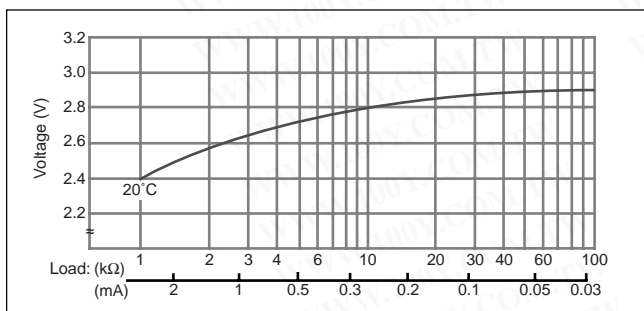

■ Capacity vs. load resistance

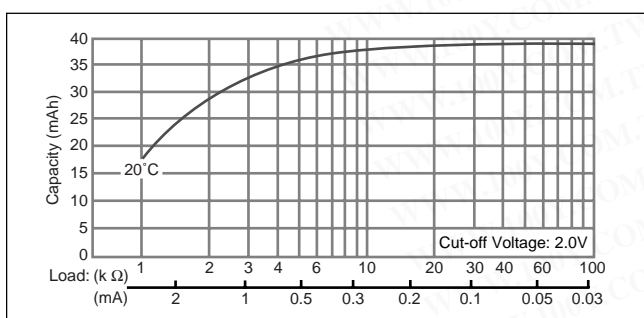

CR1612

■ Dimensions(mm)

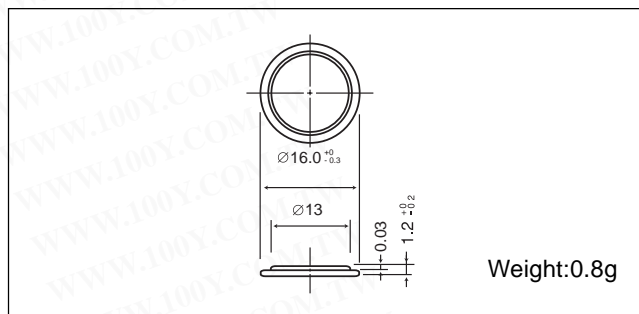

■ Specification

Nominal voltage (V)	3
Nominal capacity (mAh)	40
Continuous standard load (mA)	0.1
Operating temperature (C)	-30 ~ +60

■ Temperature Characteristics

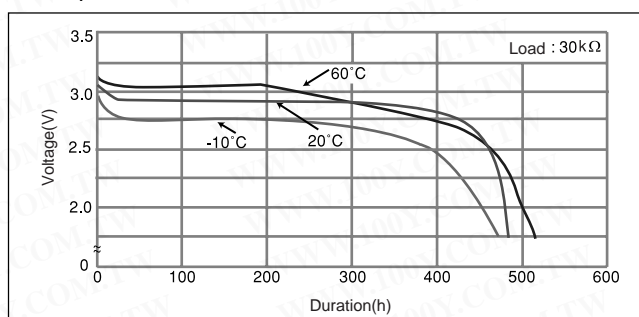

■ Operating voltage vs. load resistance (voltage at 50% discharge depth)

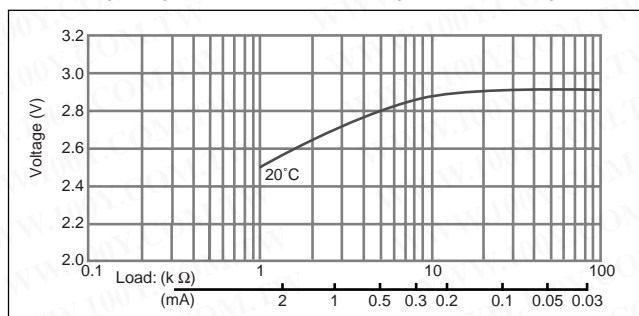

■ Capacity vs. load resistance

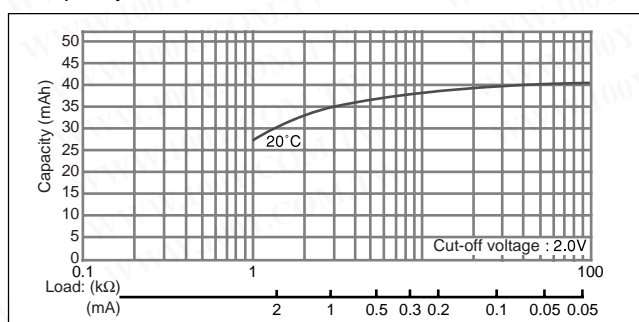

Manganese Dioxide Lithium Coin Batteries: Individual Specifications

CR1220

■ Dimensions(mm)

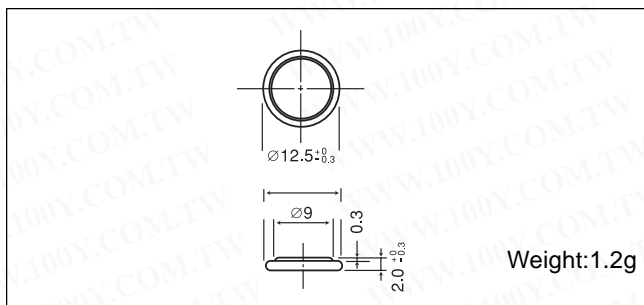

■ Specification

Nominal voltage (V)	3
Nominal capacity (mAh)	35
Continuous standard load (mA)	0.1
Operating temperature (C)	-30 ~ +60

■ Temperature Characteristics

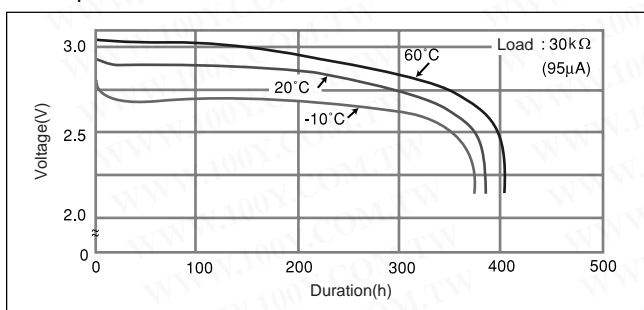

■ Operating voltage vs. load resistance (voltage at 50% discharge depth)

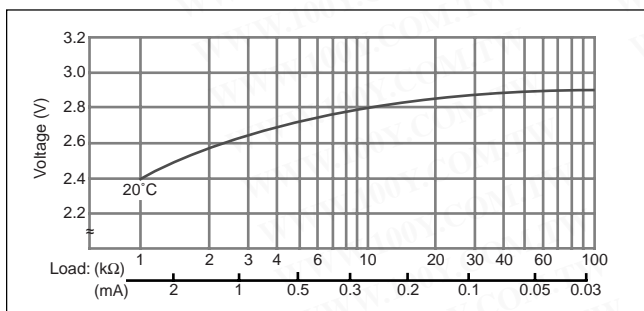

■ Capacity vs. load resistance

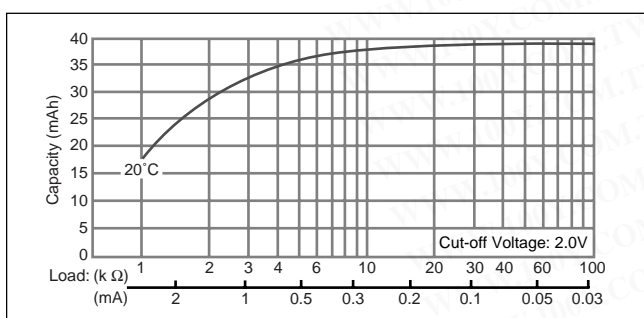

CR1612

■ Dimensions(mm)

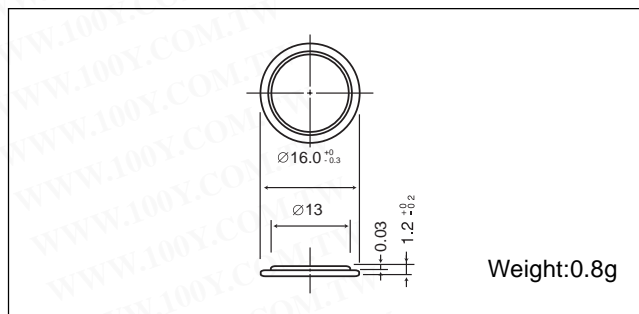

■ Specification

Nominal voltage (V)	3
Nominal capacity (mAh)	40
Continuous standard load (mA)	0.1
Operating temperature (C)	-30 ~ +60

■ Temperature Characteristics

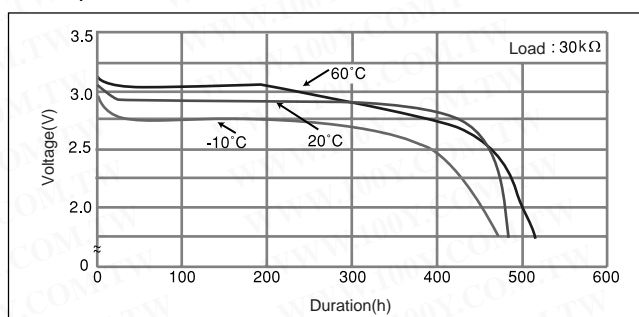

■ Operating voltage vs. load resistance (voltage at 50% discharge depth)

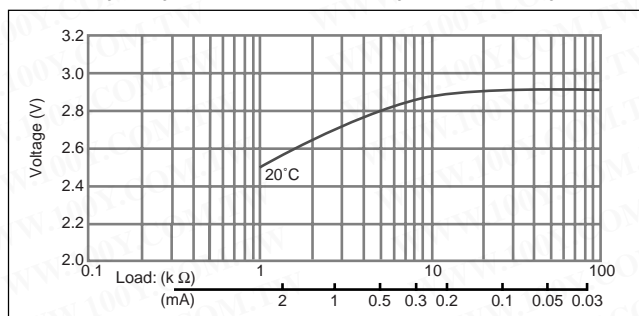

■ Capacity vs. load resistance

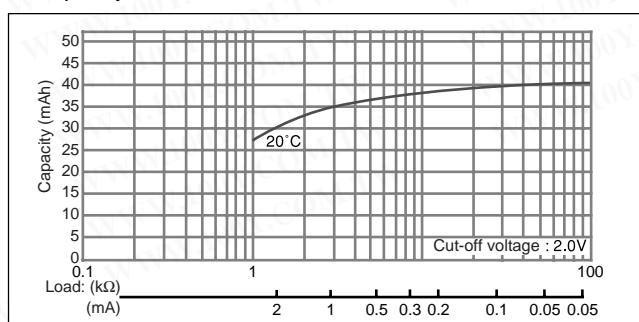

Manganese Dioxide Lithium Coin Batteries: Individual Specifications

CR1616

■ Dimensions(mm)

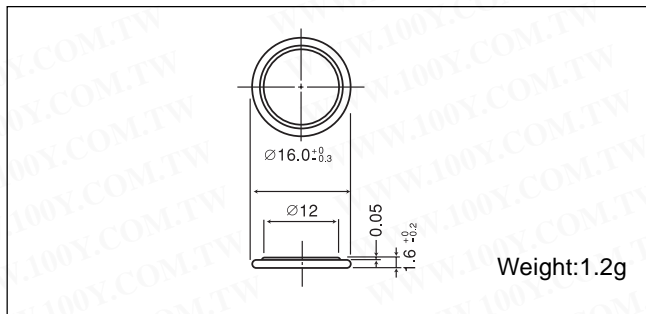

■ Specification

Nominal voltage (V)	3
Nominal capacity (mAh)	55
Continuous standard load (mA)	0.1
Operating temperature (C)	-30 ~ +60

■ Temperature Characteristics

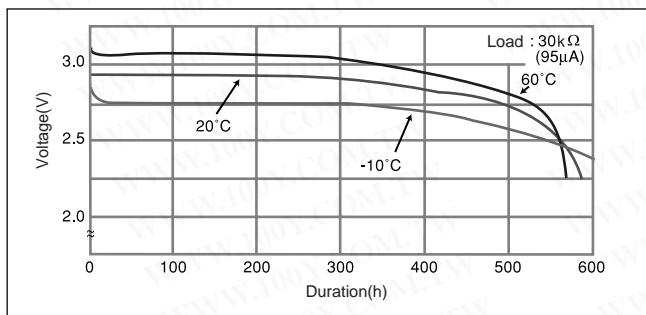

■ Operating voltage vs. load resistance (voltage at 50% discharge depth)

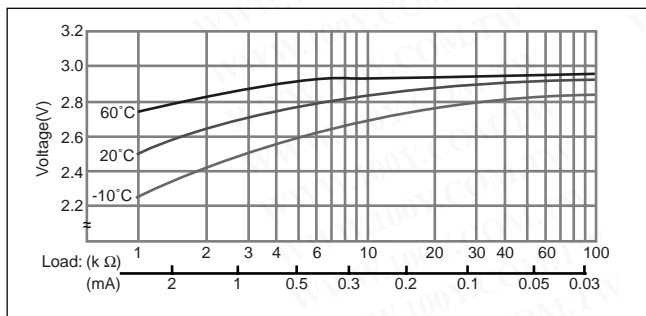

■ Capacity vs. load resistance

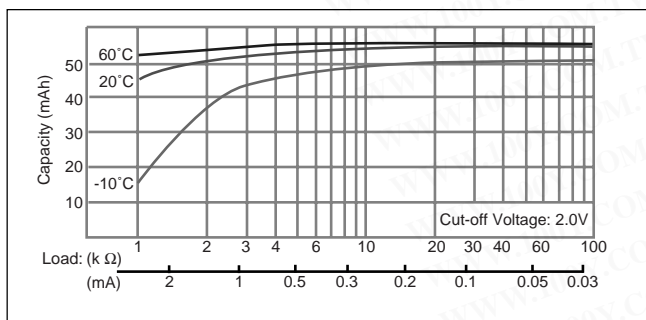

CR1620

■ Dimensions(mm)

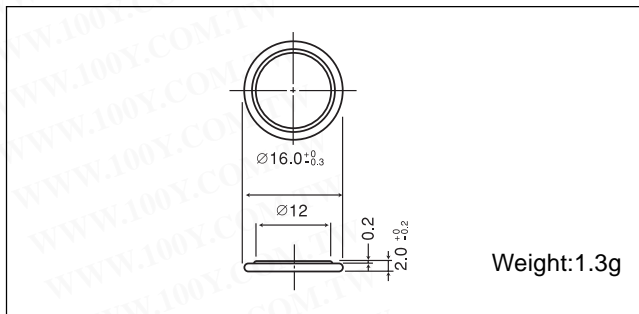

■ Specification

Nominal voltage (V)	3
Nominal capacity (mAh)	75
Continuous standard load (mA)	0.1
Operating temperature (C)	-30 ~ +60

■ Temperature Characteristics

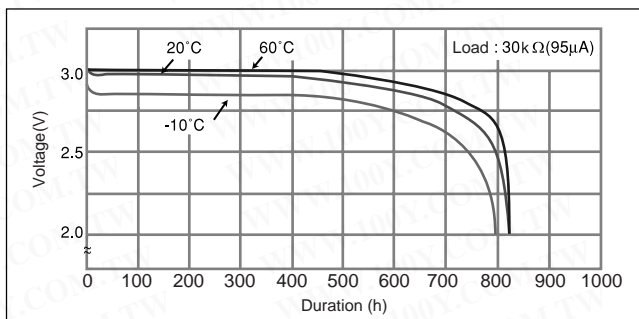

■ Operating voltage vs. load resistance (voltage at 50% discharge depth)

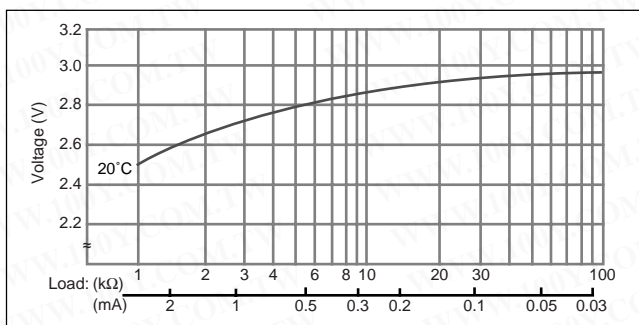

■ Capacity vs. load resistance

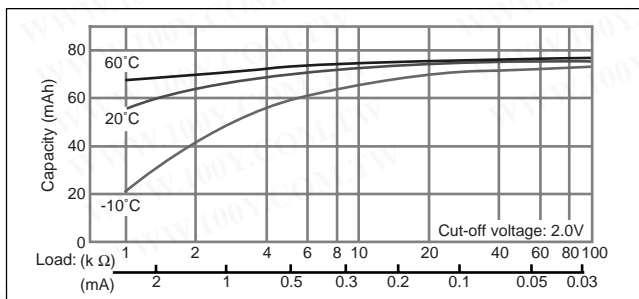

Manganese Dioxide Lithium Coin Batteries: Individual Specifications

CR1616

■ Dimensions(mm)

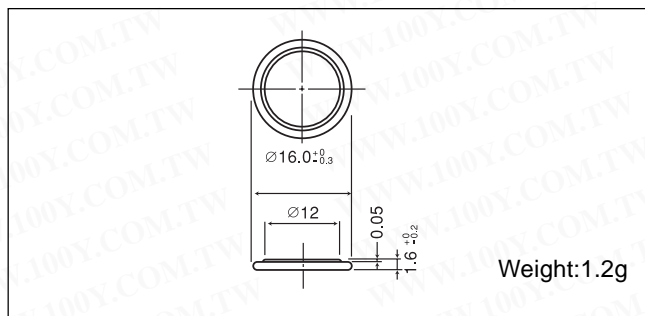

■ Specification

Nominal voltage (V)	3
Nominal capacity (mAh)	55
Continuous standard load (mA)	0.1
Operating temperature (C)	-30 ~ +60

■ Temperature Characteristics

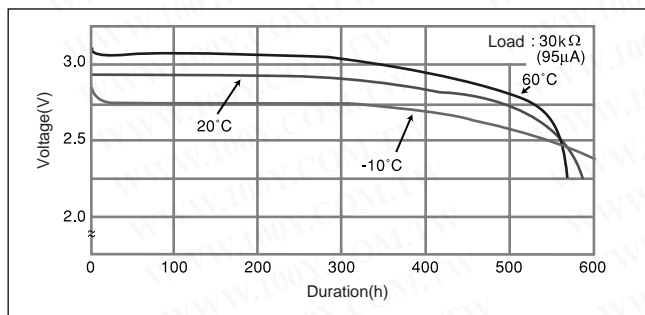

■ Operating voltage vs. load resistance (voltage at 50% discharge depth)

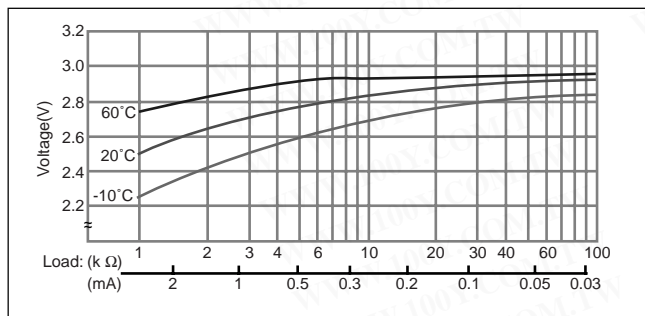

■ Capacity vs. load resistance

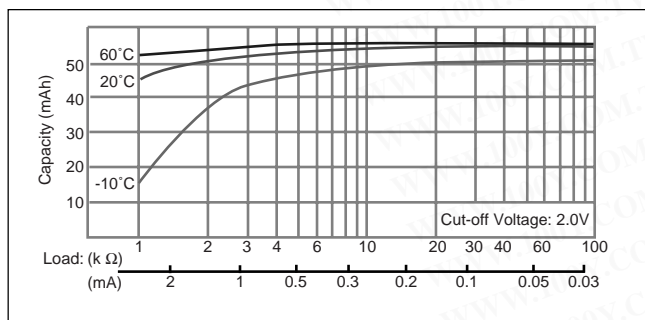

CR1620

■ Dimensions(mm)

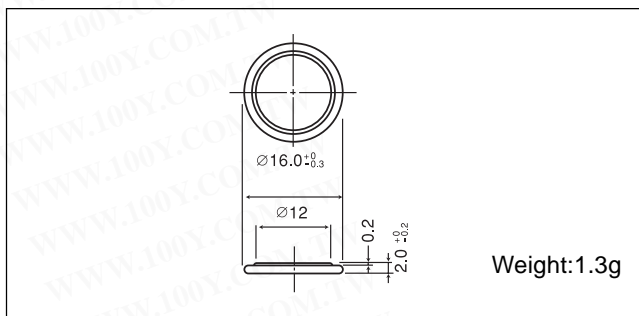

■ Specification

Nominal voltage (V)	3
Nominal capacity (mAh)	75
Continuous standard load (mA)	0.1
Operating temperature (C)	-30 ~ +60

■ Temperature Characteristics

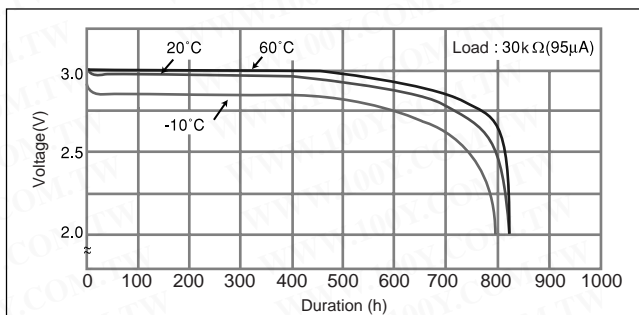

■ Operating voltage vs. load resistance (voltage at 50% discharge depth)

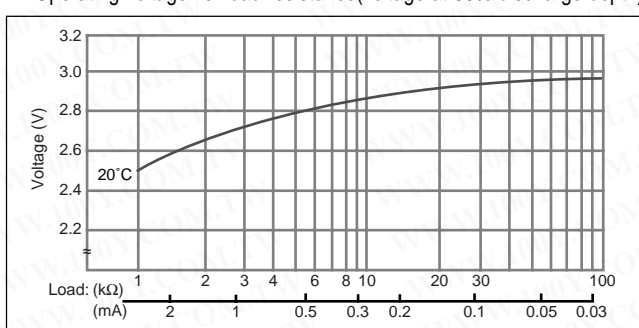

■ Capacity vs. load resistance

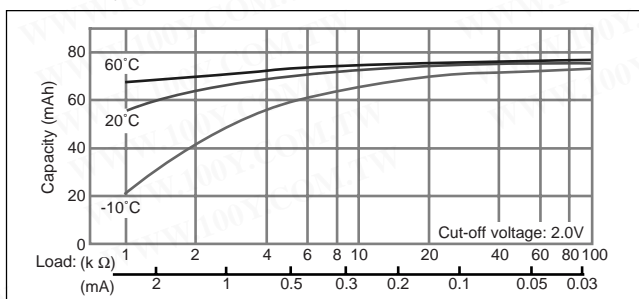

Manganese Dioxide Lithium Coin Batteries: Individual Specifications

CR1632

■ Dimensions(mm)

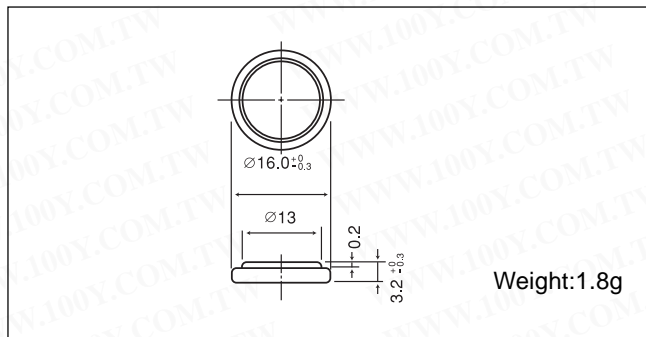

■ Specification

Nominal voltage (V)	3
Nominal capacity (mAh)	140
Continuous standard load (mA)	0.1
Operating temperature (C)	-30 ~ +60

■ Temperature Characteristics

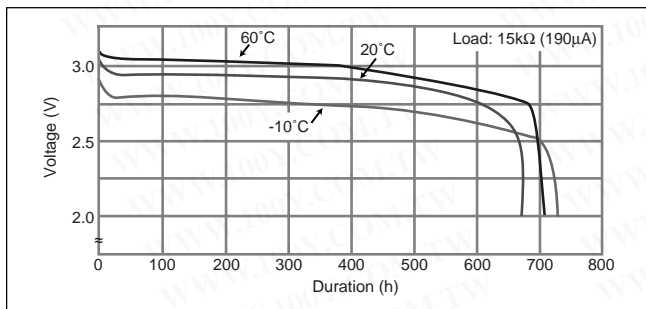

■ Operating voltage vs. load resistance (voltage at 50% discharge depth)

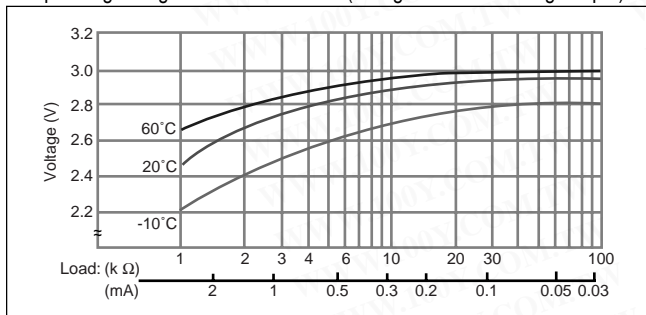

■ Capacity vs. load resistance

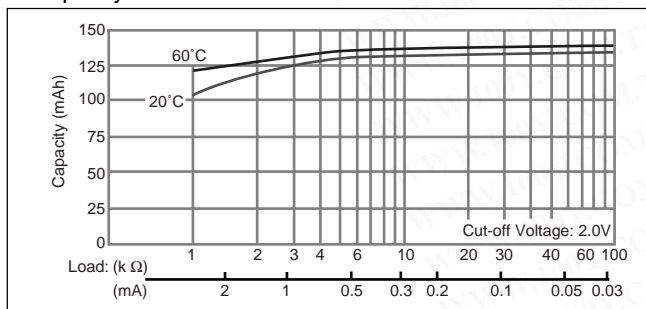

CR2012

■ Dimensions(mm)

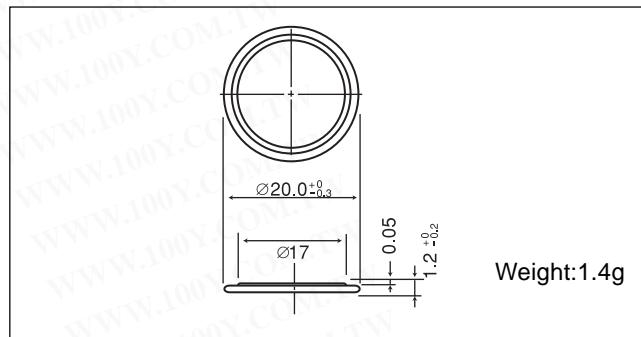

■ Specification

Nominal voltage (V)	3
Nominal capacity (mAh)	55
Continuous standard load (mA)	0.1
Operating temperature (C)	-30 ~ +60

■ Temperature Characteristics

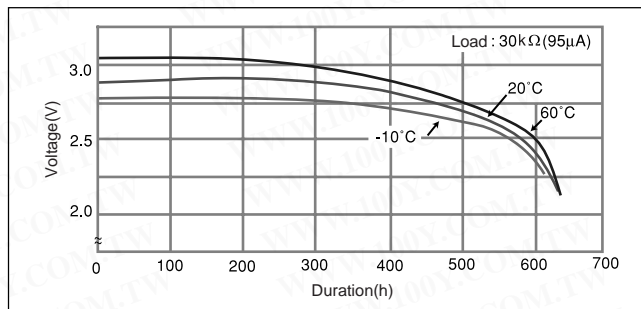

■ Operating voltage vs. load resistance (voltage at 50% discharge depth)

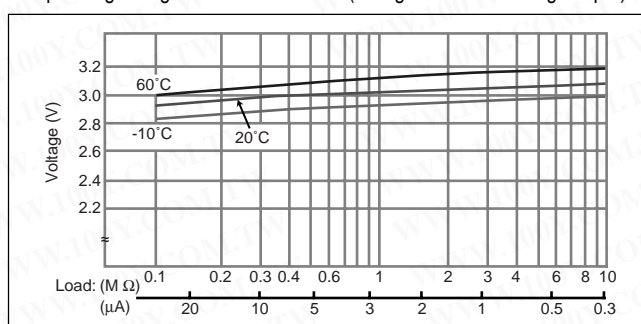

■ Capacity vs. load resistance

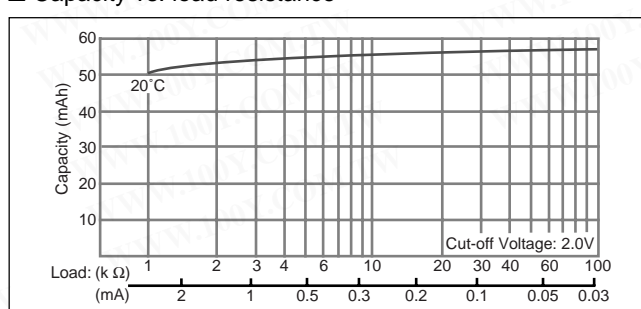

Manganese Dioxide Lithium Coin Batteries: Individual Specifications

CR2016

■ Dimensions(mm)

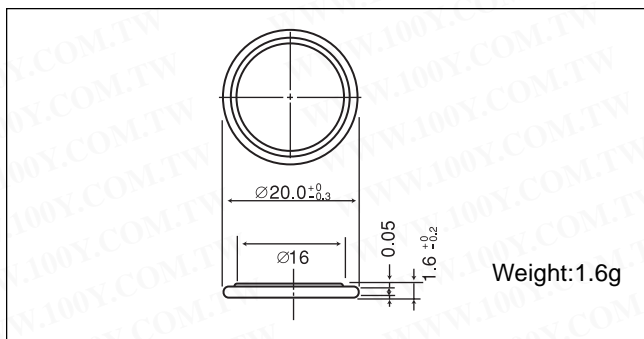

■ Specification

Nominal voltage (V)	3
Nominal capacity (mAh)	90
Continuous standard load (mA)	0.1
Operating temperature (C)	-30 ~ +60

■ Temperature Characteristics

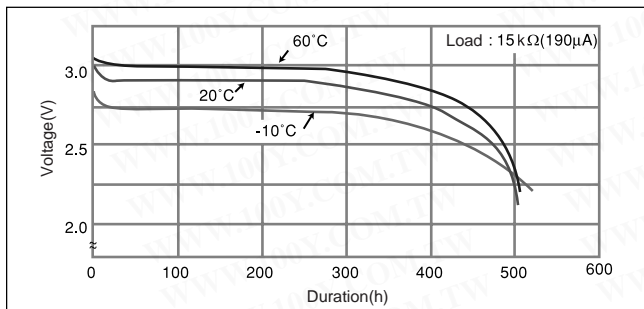

■ Operating voltage vs. load resistance (voltage at 50% discharge depth)

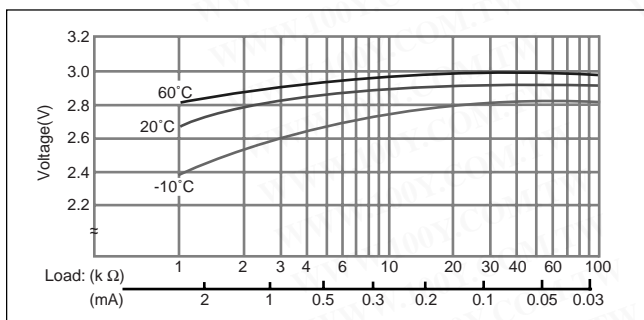

■ Capacity vs. load resistance

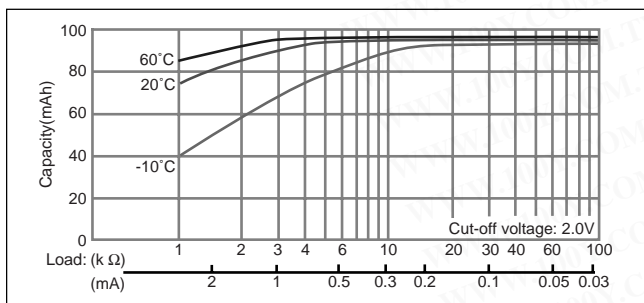

CR2025

■ Dimensions(mm)

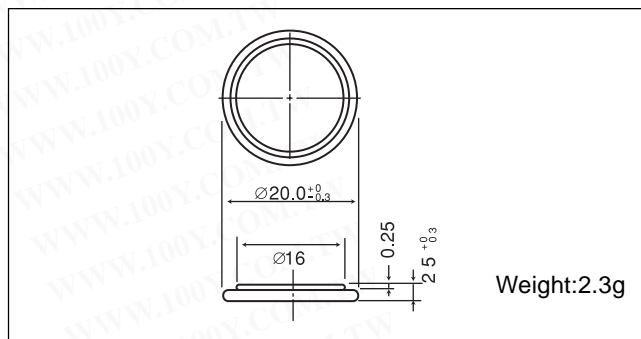

■ Specification

Nominal voltage (V)	3
Nominal capacity (mAh)	165
Continuous standard load (mA)	0.2
Operating temperature (C)	-30 ~ +60

■ Temperature Characteristics

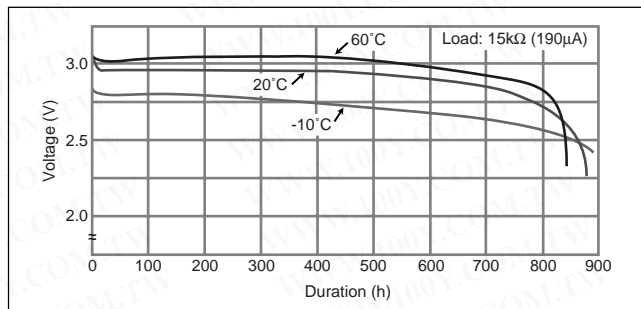

■ Operating voltage vs. load resistance (voltage at 50% discharge depth)

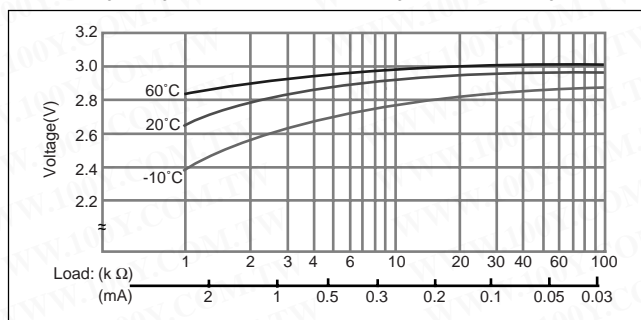

■ Capacity vs. load resistance

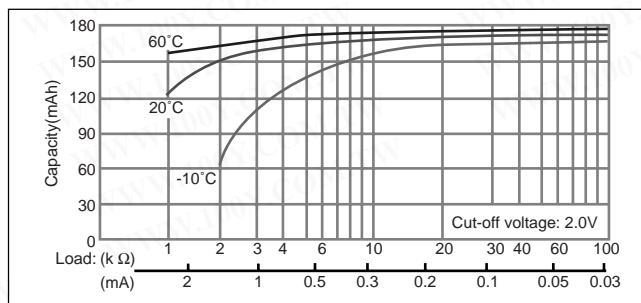

Manganese Dioxide Lithium Coin Batteries: Individual Specifications

CR2016

■ Dimensions(mm)

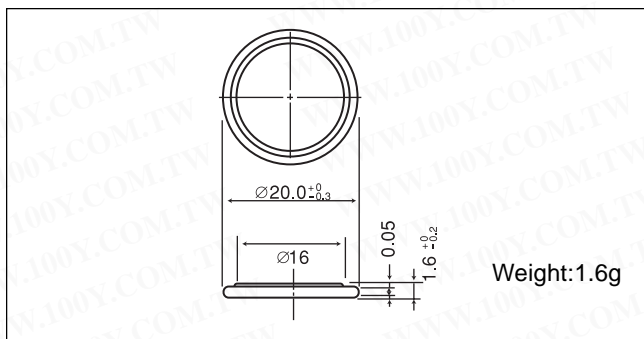

■ Specification

Nominal voltage (V)	3
Nominal capacity (mAh)	90
Continuous standard load (mA)	0.1
Operating temperature (C)	-30 ~ +60

■ Temperature Characteristics

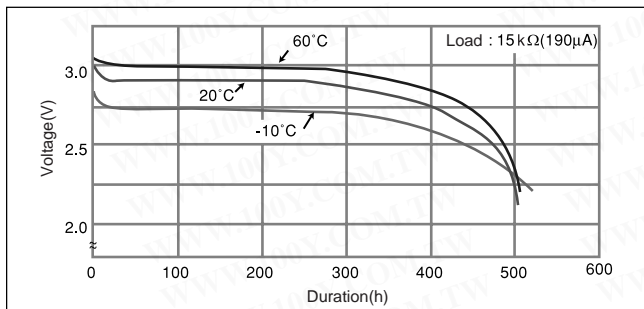

■ Operating voltage vs. load resistance (voltage at 50% discharge depth)

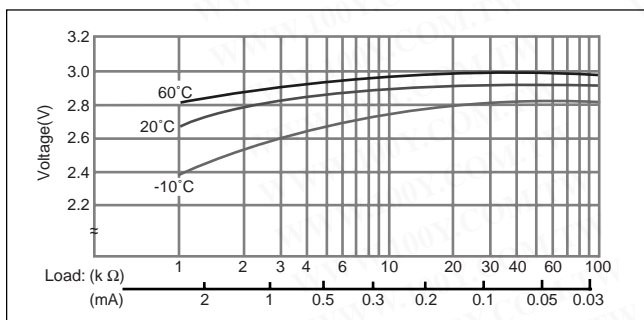

■ Capacity vs. load resistance

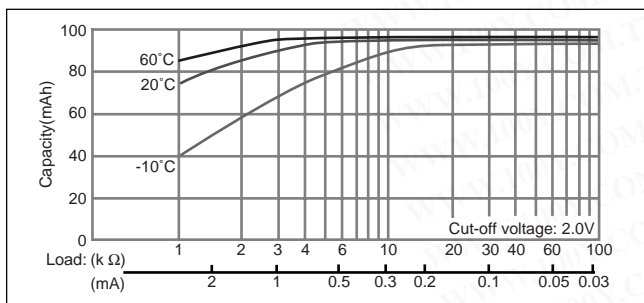

CR2025

■ Dimensions(mm)

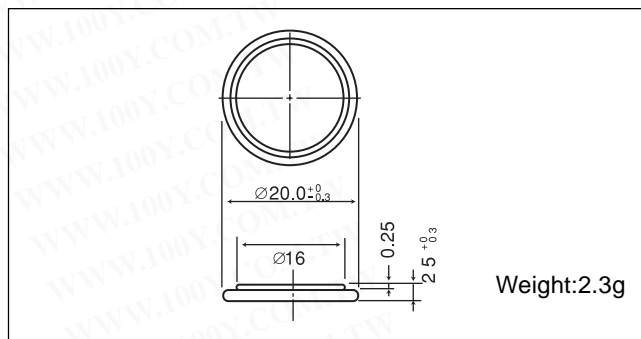

■ Specification

Nominal voltage (V)	3
Nominal capacity (mAh)	165
Continuous standard load (mA)	0.2
Operating temperature (C)	-30 ~ +60

■ Temperature Characteristics

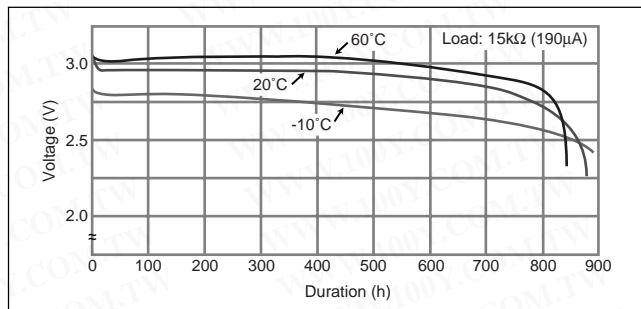

■ Operating voltage vs. load resistance (voltage at 50% discharge depth)

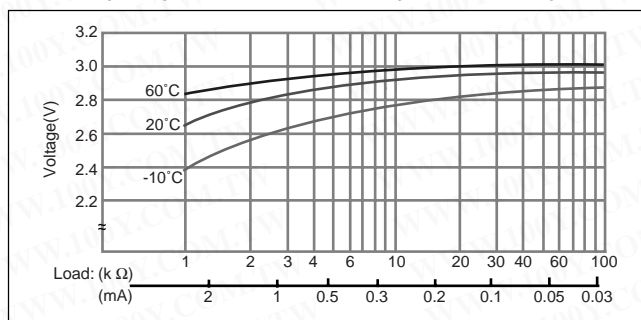

■ Capacity vs. load resistance

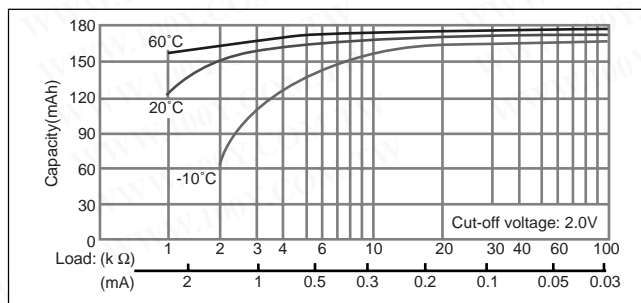

Manganese Dioxide Lithium Coin Batteries: Individual Specifications

CR2032

□ Dimensions(mm)

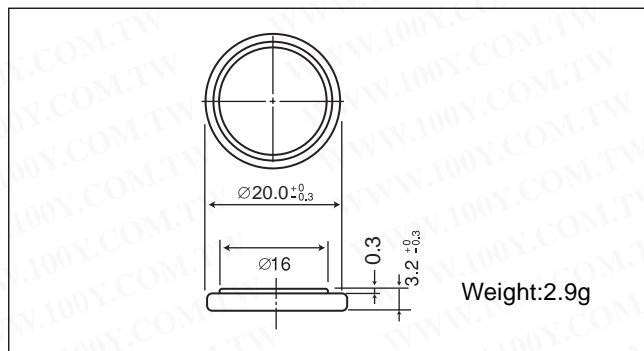

□ Specification

Nominal voltage (V)	3
Nominal capacity (mAh)	225
Continuous standard load (mA)	0.2
Operating temperature (C)	-30 ~ +60

□ Temperature Characteristics

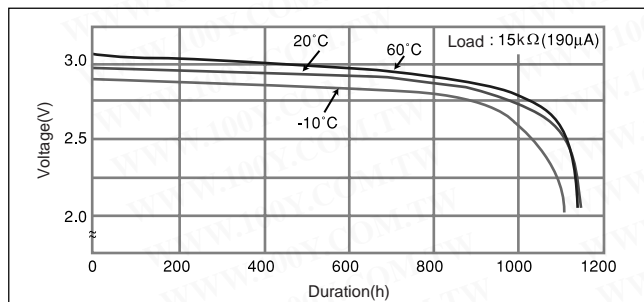

□ Operating voltage vs. load resistance (voltage at 50% discharge depth)

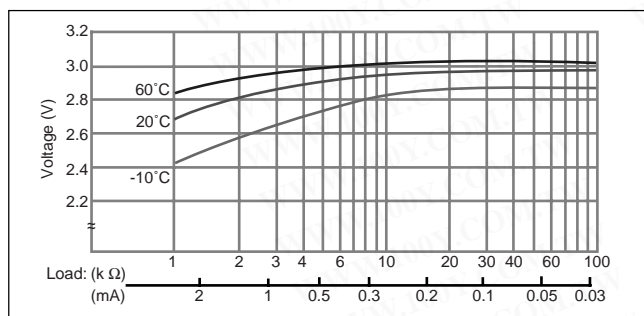

□ Capacity vs. load resistance

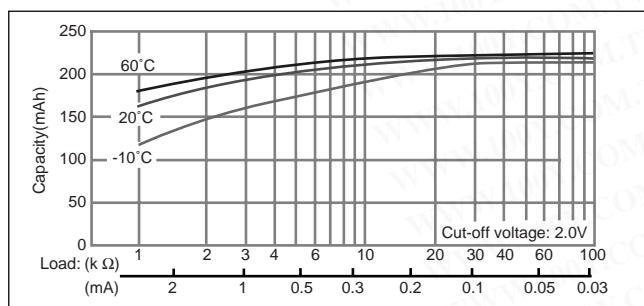

CR2330

□ Dimensions(mm)

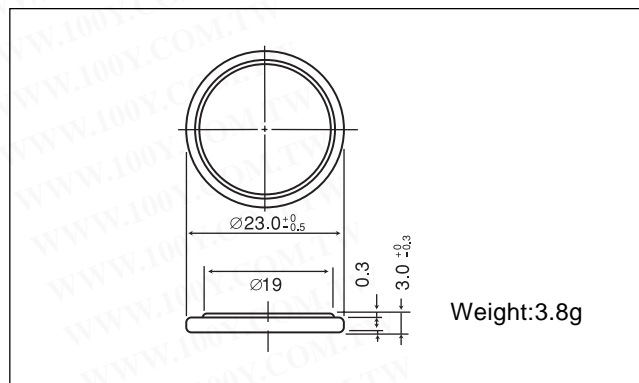

□ Specification

Nominal voltage (V)	3
Nominal capacity (mAh)	265
Continuous standard load (mA)	0.2
Operating temperature (C)	-30 ~ +60

□ Temperature Characteristics

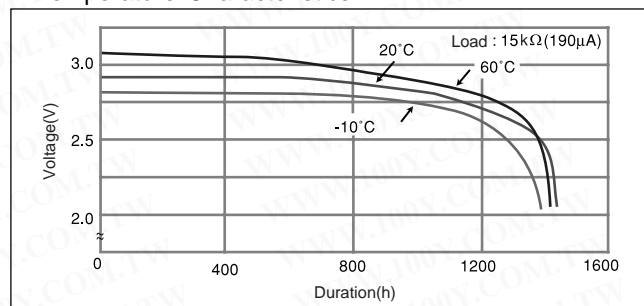

□ Operating voltage vs. load resistance (voltage at 50% discharge depth)

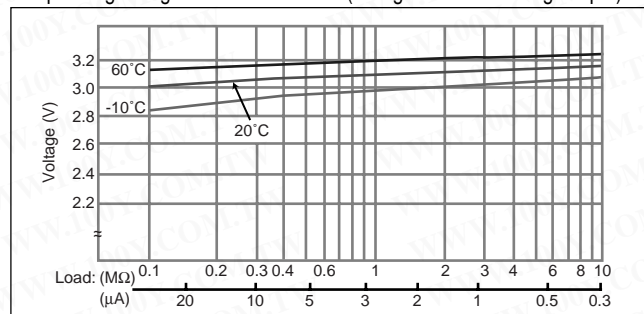

□ Capacity vs. load resistance

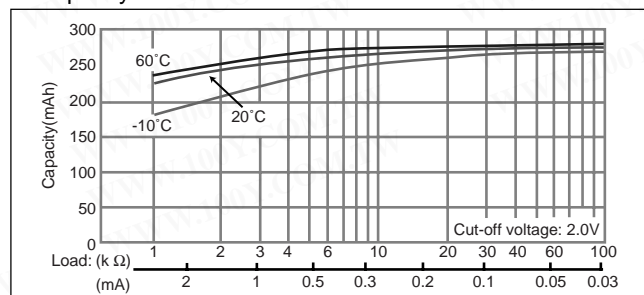

Manganese Dioxide Lithium Coin Batteries: Individual Specifications

CR2032

□ Dimensions(mm)

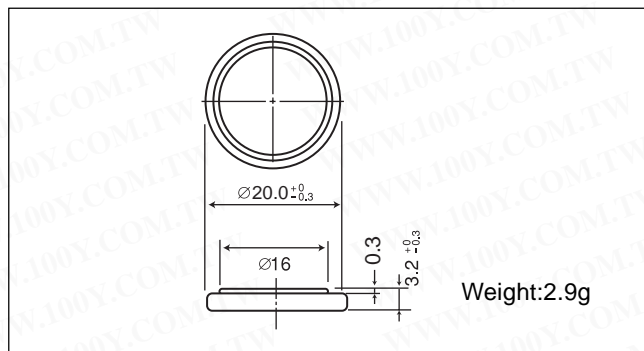

□ Specification

Nominal voltage (V)	3
Nominal capacity (mAh)	225
Continuous standard load (mA)	0.2
Operating temperature (C)	-30 ~ +60

□ Temperature Characteristics

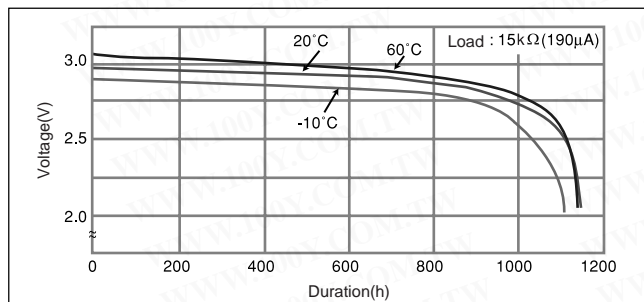

□ Operating voltage vs. load resistance (voltage at 50% discharge depth)

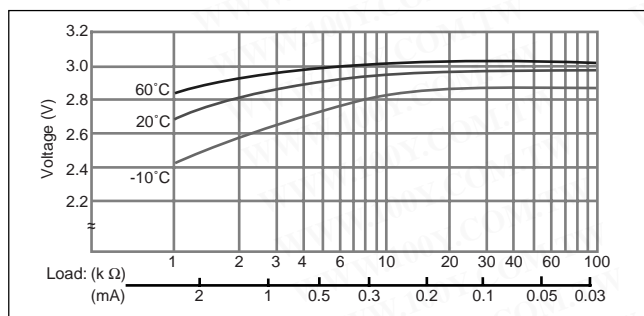

□ Capacity vs. load resistance

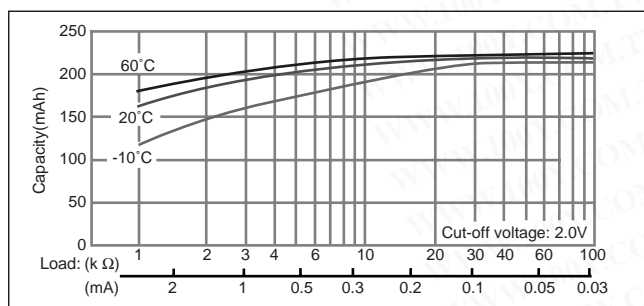

CR2330

□ Dimensions(mm)

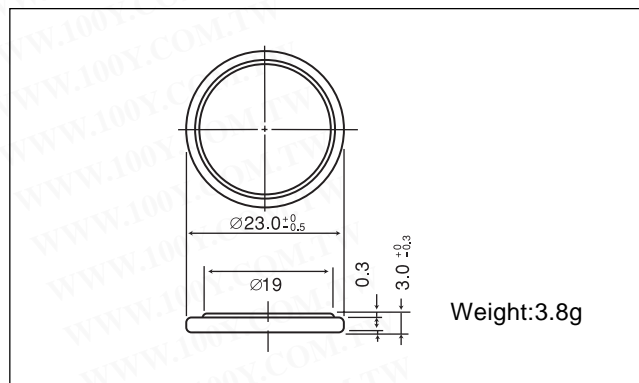

□ Specification

Nominal voltage (V)	3
Nominal capacity (mAh)	265
Continuous standard load (mA)	0.2
Operating temperature (C)	-30 ~ +60

□ Temperature Characteristics

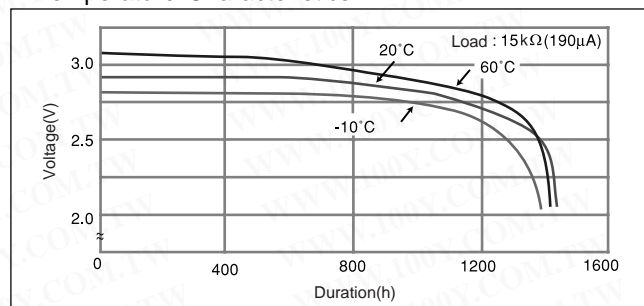

□ Operating voltage vs. load resistance (voltage at 50% discharge depth)

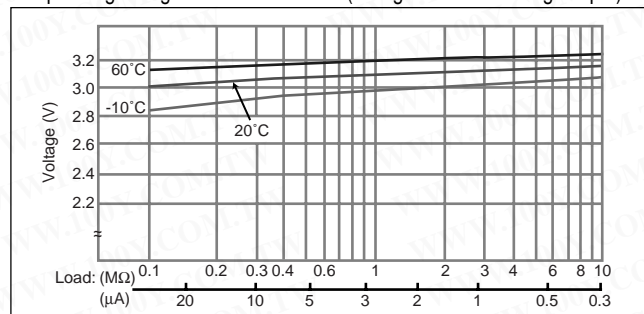

□ Capacity vs. load resistance

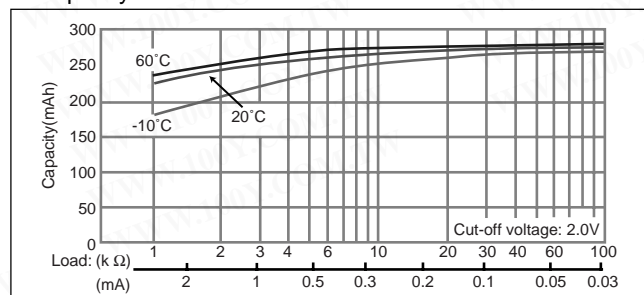

Manganese Dioxide Lithium Coin Batteries: Individual Specifications

CR2354

□ Dimensions(mm)

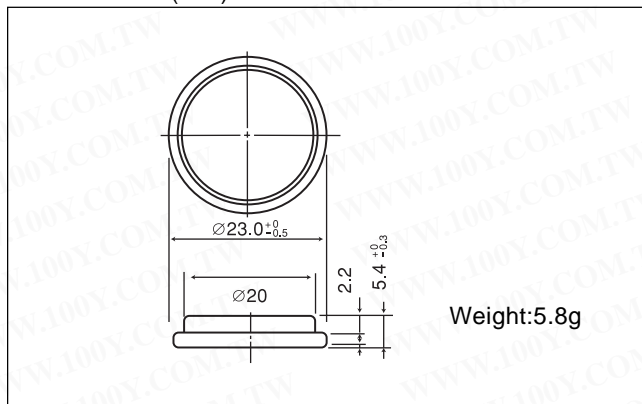

□ Specification

Nominal voltage (V)	3
Nominal capacity (mAh)	560
Continuous standard load (mA)	0.2
Operating temperature (C)	-30 ~ +60

□ Temperature Characteristics

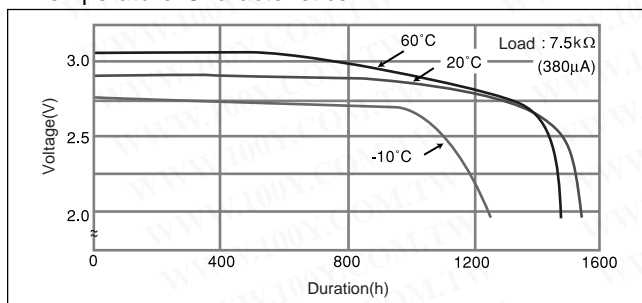

□ Operating voltage vs. load resistance (voltage at 50% discharge depth)

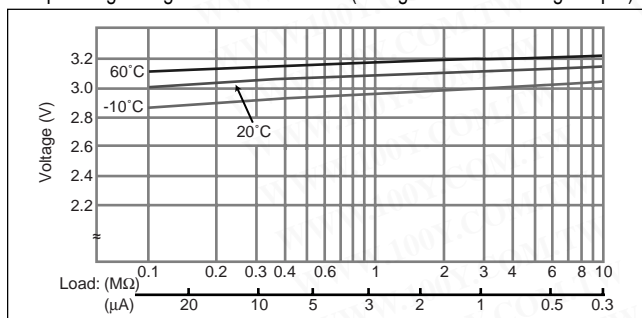

□ Capacity vs. load resistance

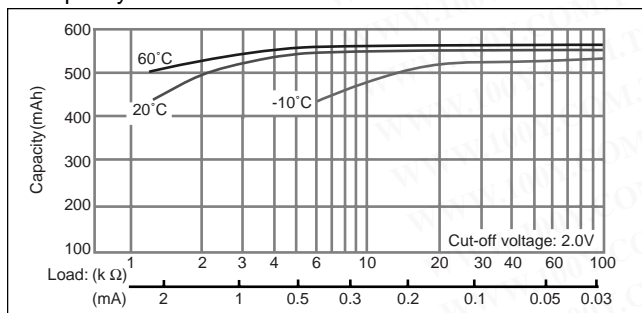

CR2412

□ Dimensions(mm)

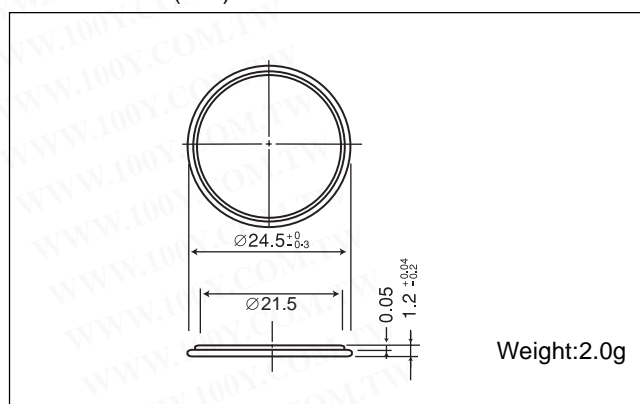

□ Specification

Nominal voltage (V)	3
Nominal capacity (mAh)	100
Continuous standard load (mA)	0.2
Operating temperature (C)	-30 ~ +60

□ Temperature Characteristics

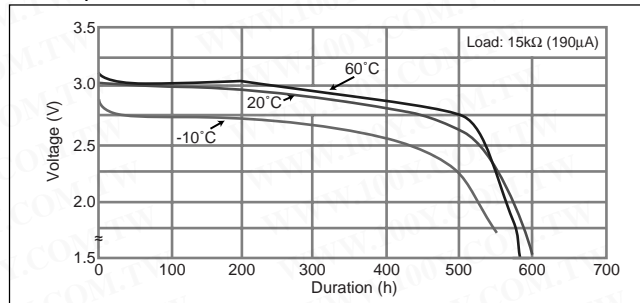

□ Operating voltage vs. load resistance (voltage at 50% discharge depth)

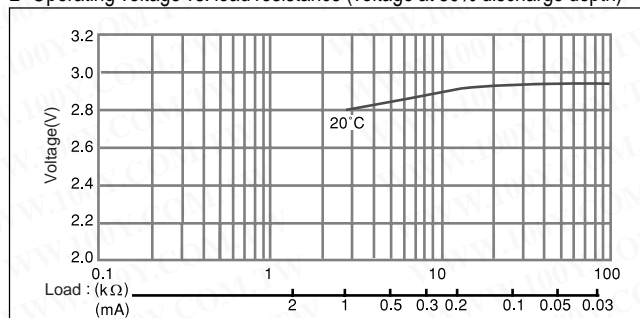

□ Capacity vs. load resistance

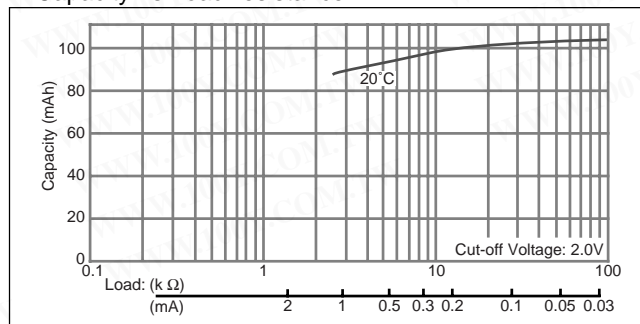

Manganese Dioxide Lithium Coin Batteries: Individual Specifications

CR2354

□ Dimensions(mm)

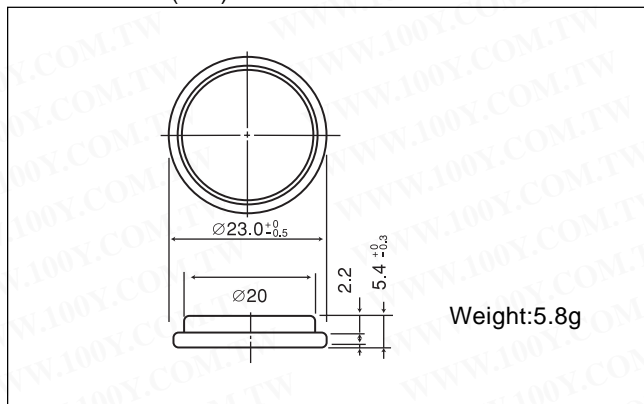

□ Specification

Nominal voltage (V)	3
Nominal capacity (mAh)	560
Continuous standard load (mA)	0.2
Operating temperature (C)	-30 ~ +60

□ Temperature Characteristics

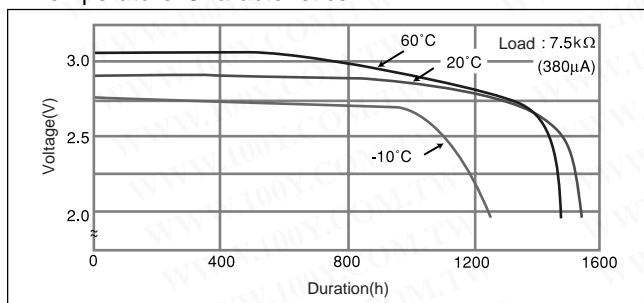

□ Operating voltage vs. load resistance (voltage at 50% discharge depth)

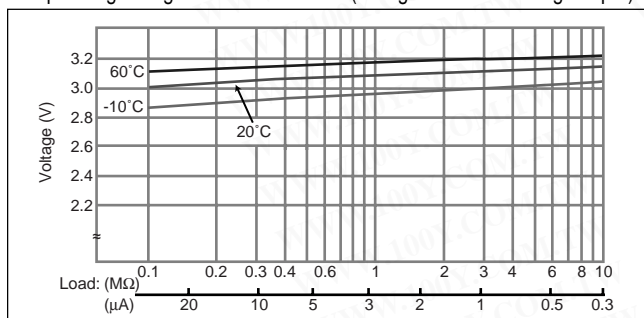

□ Capacity vs. load resistance

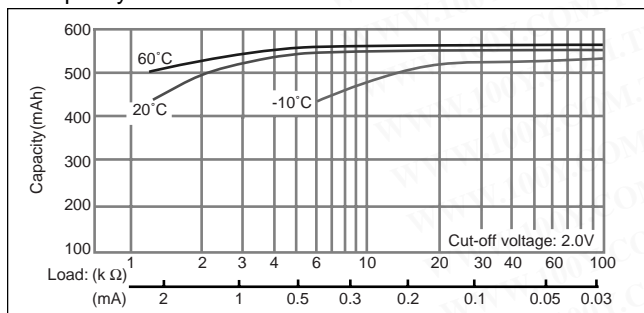

CR2412

□ Dimensions(mm)

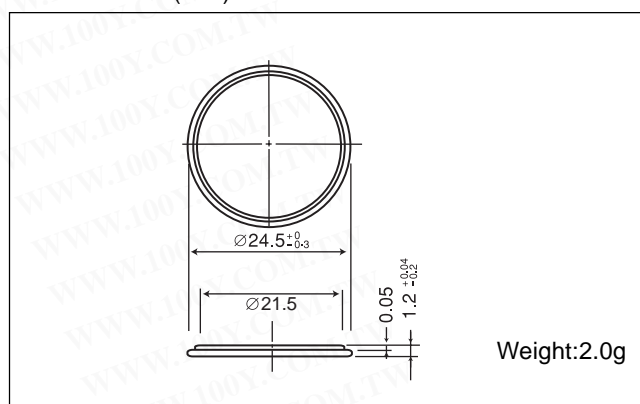

□ Specification

Nominal voltage (V)	3
Nominal capacity (mAh)	100
Continuous standard load (mA)	0.2
Operating temperature (C)	-30 ~ +60

□ Temperature Characteristics

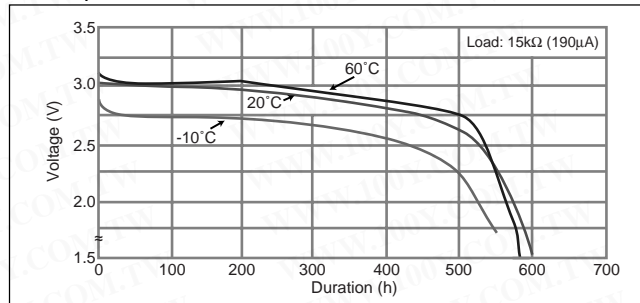

□ Operating voltage vs. load resistance (voltage at 50% discharge depth)

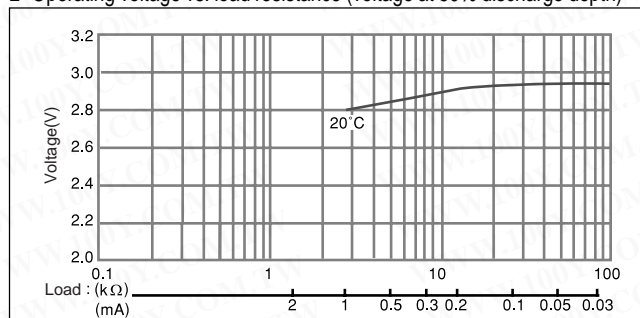

□ Capacity vs. load resistance

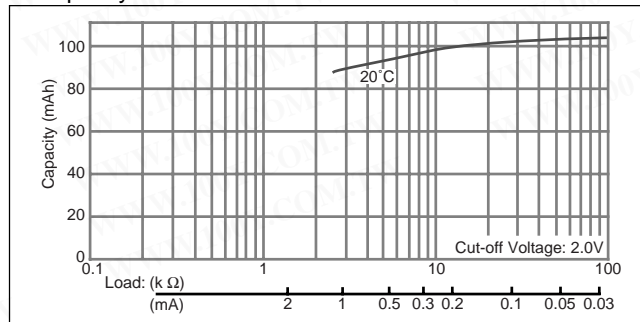

Manganese Dioxide Lithium Coin Batteries: Individual Specifications

CR2450

■ Dimensions(mm)

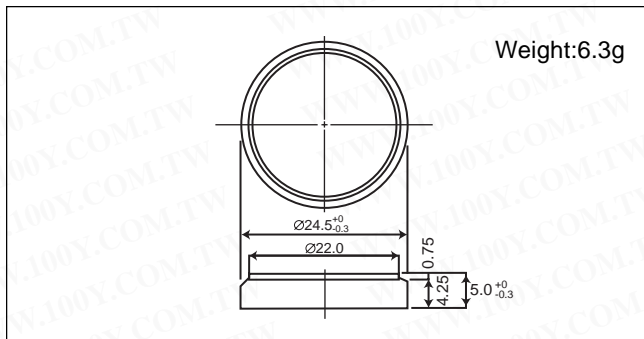

■ Specification

Nominal voltage (V)	3
Nominal capacity (mAh)	620
Continuous standard load (mA)	0.2
Operating temperature (C)	-30 ~ +60

■ Temperature Characteristics

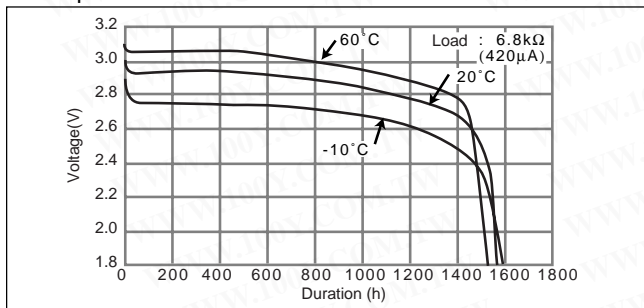

■ Operating voltage vs. load resistance (voltage at 50% discharge depth)

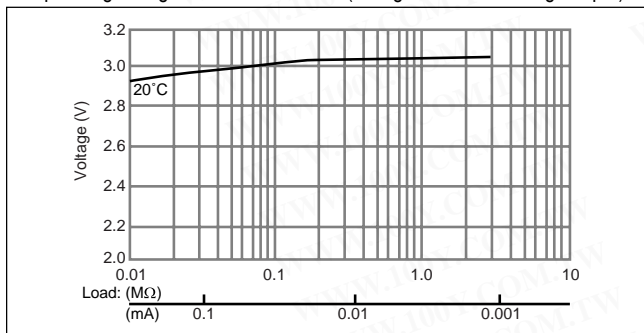

■ Capacity vs. load resistance

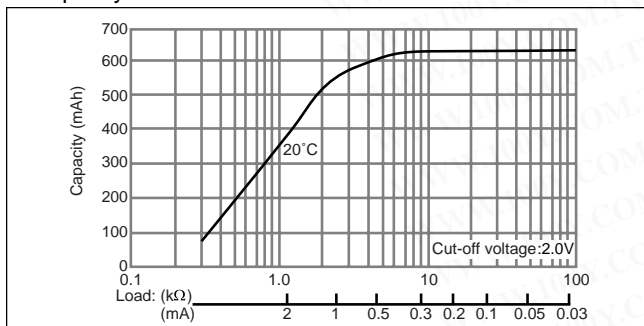

CR2477

■ Dimensions(mm)

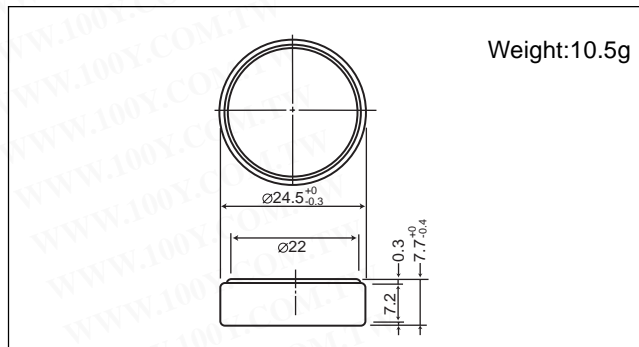

■ Specification

Nominal voltage (V)	3
Nominal capacity (mAh)	1,000
Continuous standard load (mA)	0.2
Operating temperature (C)	-30 ~ +60

■ Temperature Characteristics

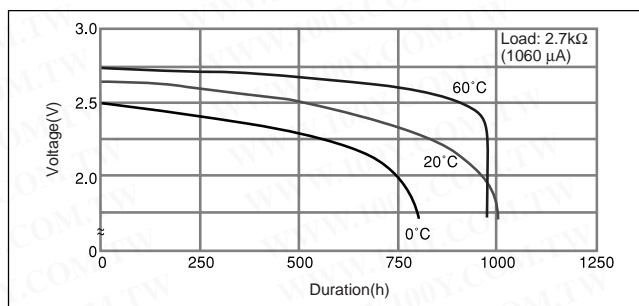

■ Operating voltage vs. load resistance (voltage at 50% discharge depth)

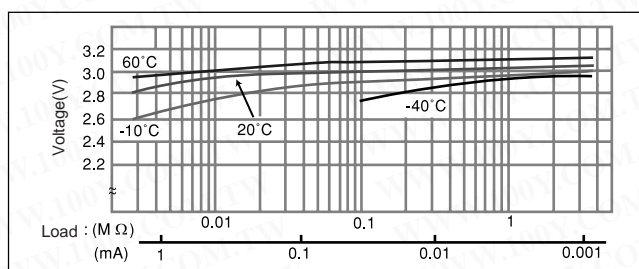

■ Capacity vs. load resistance

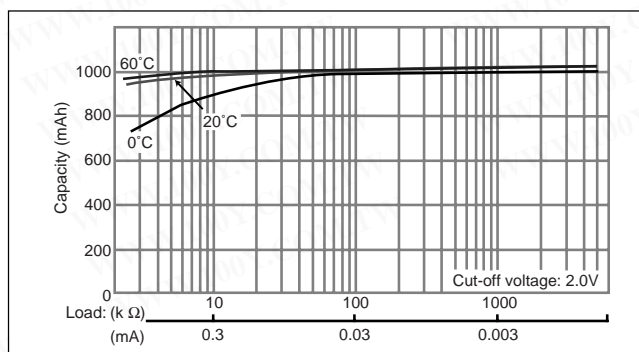

Manganese Dioxide Lithium Coin Batteries: Individual Specifications

CR2450

■ Dimensions(mm)

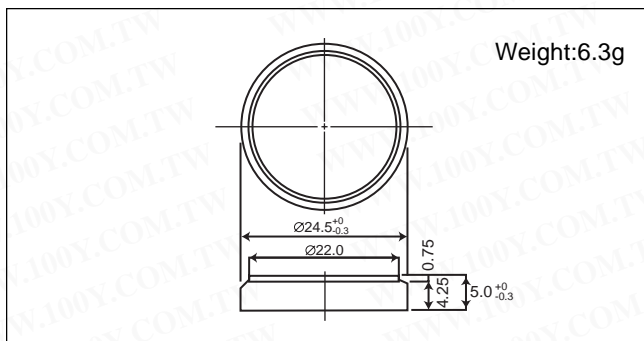

■ Specification

Nominal voltage (V)	3
Nominal capacity (mAh)	620
Continuous standard load (mA)	0.2
Operating temperature (C)	-30 ~ +60

■ Temperature Characteristics

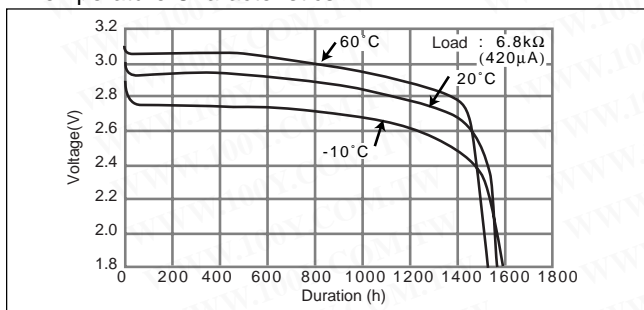

■ Operating voltage vs. load resistance (voltage at 50% discharge depth)

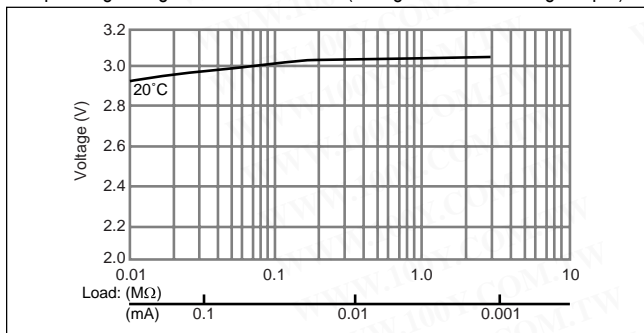

■ Capacity vs. load resistance

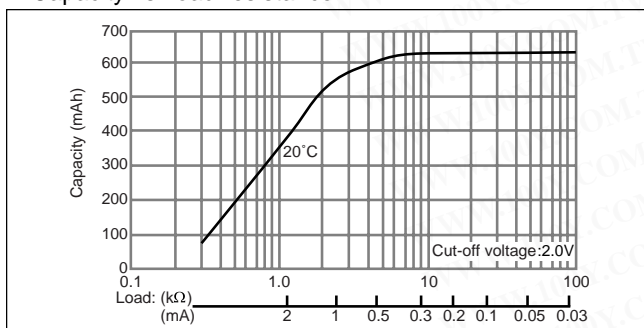

CR2477

■ Dimensions(mm)

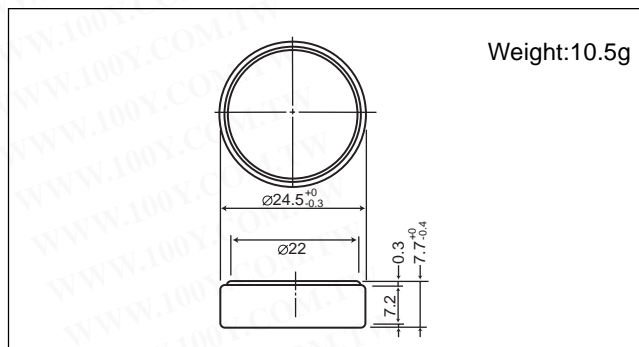

■ Specification

Nominal voltage (V)	3
Nominal capacity (mAh)	1,000
Continuous standard load (mA)	0.2
Operating temperature (C)	-30 ~ +60

■ Temperature Characteristics

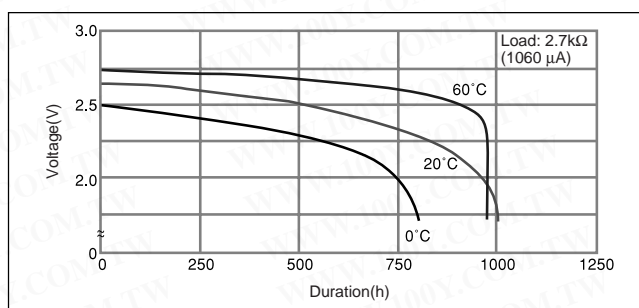

■ Operating voltage vs. load resistance (voltage at 50% discharge depth)

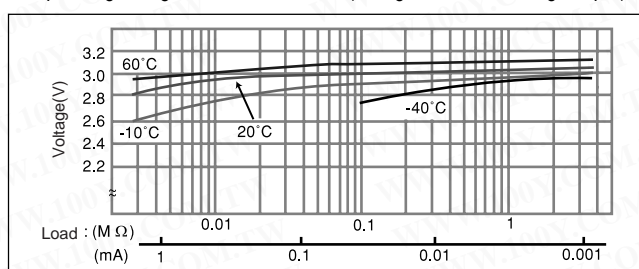

■ Capacity vs. load resistance

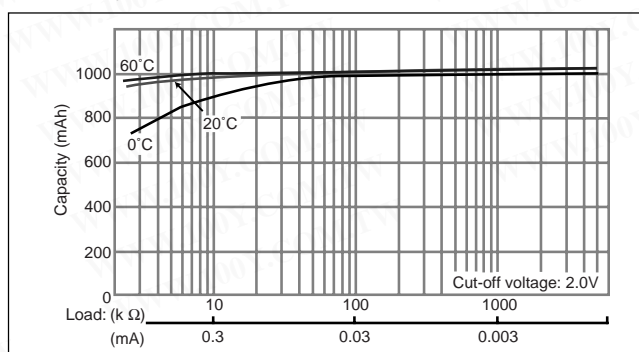

Manganese Dioxide Lithium Coin Batteries: Individual Specifications

CR3032

□ Dimensions(mm)

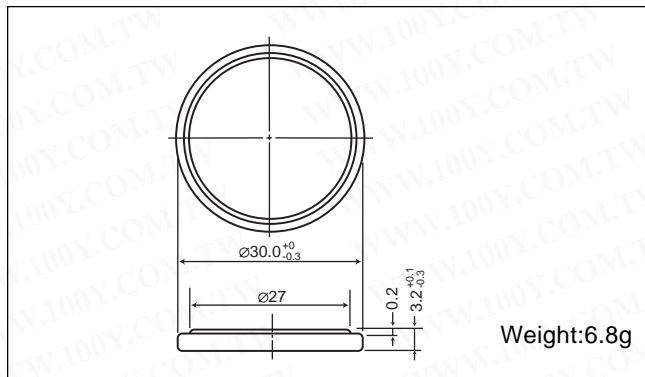

勝特力材料 886-3-5753170
 勝特力电子(上海) 86-21-34970699
 勝特力电子(深圳) 86-755-83298787
[Http://www.100y.com.tw](http://www.100y.com.tw)

□ Specification

Nominal voltage (V)	3
Nominal capacity (mAh)	500
Continuous standard load (mA)	0.2
Operating temperature (C)	-30 ~ +60

□ Temperature Characteristics

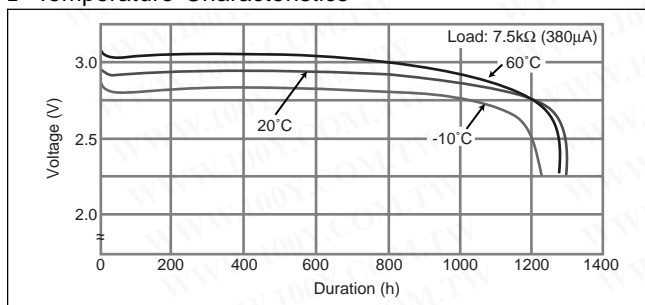

□ Operating voltage vs. load resistance (voltage at 50% discharge depth)

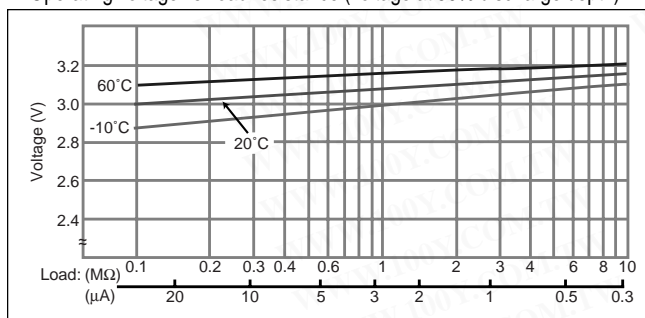

□ Capacity vs. load resistance

